



CP 130 Sliding Door

CP 130 is a premium insulated sliding system combining high weather performance with enhanced security and great aesthetics.

Available in slide or lift-and-slide variants, this sliding door system is designed with ease of use in mind. The system not only glides smoothly, it also has a slim-line mid-section interlock to maximise the glass area and can be specified with our integrated ventilation system, Ventalis.

With a maximum vent weight of 300 kg and a maximum height of 2.7 m, this versatile system is ideal for most residential applications. Our revolutionary open corner system for the CP 130-LS makes it possible to open up two sides of a room with no corner post, creating a truly remarkable architectural feature.

Thermal insulation is important for most people in the UK, and the CP 130 offers industry-leading performance in this respect. With a double glazed sealed unit, the CP 130 can offer a whole door U-value as low as 1.5 W/m²K; with triple glazing, this can be further improved to a phenomenal 1.1 W/m²K.

Reynaers Ltd • 111 Hollymoor Way • Northfield • Birmingham • B31 5HE
 T 0121 421 1999 E homeuk@reynaers.com
reynaersathome.co.uk

Part of the Reynaers family



101671 RAH June 2019



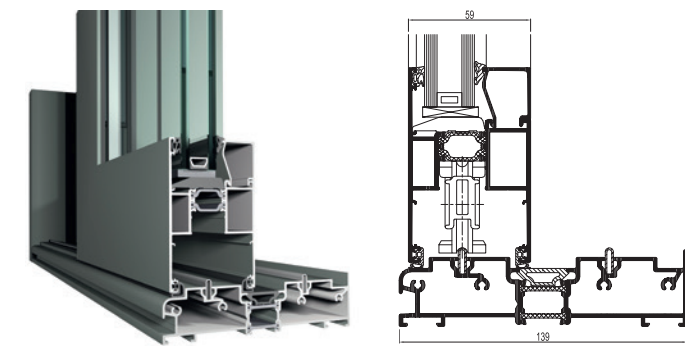

Letting the outside in

A sliding door opens up a multitude of possibilities. Open this door just a few centimetres for a little fresh air, a little wider to slip out into the garden or open it all the way to really let the outside in. This versatile door creates an extra feeling of space and generates more natural light within the home.

CP 130 Slide and CP 130 Lift & Slide

All types of CP 130 sliding door use durable, stainless steel wheels and rails for ease of operation. In the case of the lift and slide system, the sliding door is lifted slightly before opening or closing. This reduces the friction and makes the operation smooth and effortless. In the closed position, the lift and slide door is lowered onto the track, providing additional weather resistance.

Monorail, duo rail or 3-rail

A **monorail system** combines a moving part with a fixed glazed element that is anchored directly into the outer frame profile for a minimalistic look. The fixed pane is normally set to the inside of the track and is internally beaded.

Monorail	CP 130	CP 130-LS
	X	X

A **duo rail system** integrates two glazed opening vents with an identical appearance, giving an aesthetically pleasing and versatile sliding door. Both vents can be made as sliding elements, giving total flexibility.

Duo rail	CP 130	CP 130-LS
	X	X

A **3-rail system** makes it possible for a third opening vent to be installed. This solution allows the user to slide door leaves one and two behind leaf three, opening up two-thirds of the width to the garden.

3-rail	CP 130	CP 130-LS
	X	X

Technical characteristics

Variants	CP 130 Monorail, duo rail and 3-rail	CP 130-LS Monorail, duo rail and 3-rail	
Visible width / height	Frame / Threshold	50 / 28 mm	20 / 28 / 35 / 40 mm
	Vent	94 mm	94 mm
	T-profile	from 76 mm to 154 mm	from 76 mm to 154 mm
	Meeting section	69 / 98 mm	69 / 98 mm
	Meeting section 4 doors	194 mm	194 mm
Overall system depth	Frame	Monorail: 130 mm Duo rail: 110 / 130 / 139 mm 3-rail: 181 / 210 mm	Monorail: 139 mm Duo rail: 139 mm 3-rail: 210 mm
	Vent	59 mm	59 mm
Maximum element height	2700 mm	2700 mm	
Maximum vent weight	300 kg	300 kg	
Rebate height	25 mm	25 mm	
Glass thickness	up to 43 mm	up to 43 mm	
Glazing method	Dry glazing with EPDM or neutral silicones		
Thermal insulation	23 mm, 18.6 mm and 32 mm fibreglass reinforced polyamide strips	23 mm and 32 mm fibreglass reinforced polyamide strips	
HI variant	extra insulation gaskets	extra insulation gaskets	

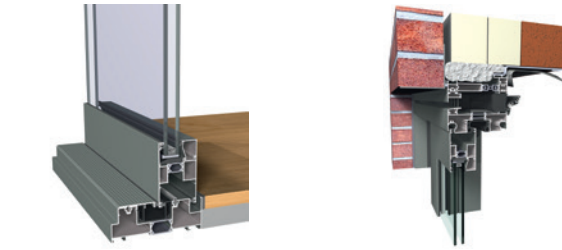

Flush floor integration

Ventalis integration

CP 130-LS open corner system

Designed exclusively for the CP 130-LS duo rail system, this clever corner system comprises two sliding units that meet at a corner. Closed, the thick double weather gaskets protect against the elements; slide the two doors apart to open up the whole corner with no fixed corner post to get in the way or obstruct the view.

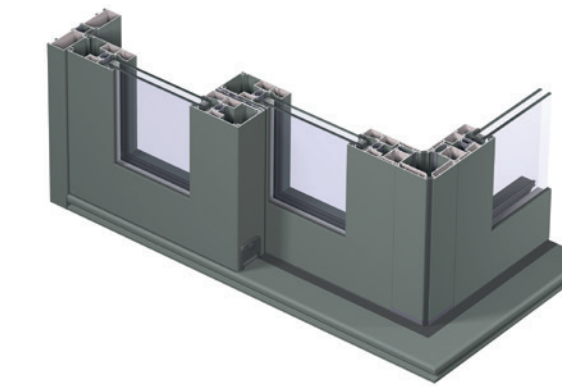

Performances

Energy		Uf-value down to 2.35 W/m ² K, depending on the frame/vent combination									
	Thermal Insulation ⁽¹⁾ EN 10077-2										
Comfort		Rw (C; Ctr) = 35 (-2;-6) dB / 39 (-1;-3) dB, depending on glazing type									
	Acoustic performance ⁽²⁾ EN ISO 140-3; EN ISO 717-1										
	Air-tightness, max. test pressure ⁽³⁾ EN 12207	1 (150 Pa)	2 (300 Pa)	3 (600 Pa)	4 (600 Pa)						
	Water-tightness ⁽⁴⁾ EN 12208	1A (0 Pa)	2A (50 Pa)	3A (100 Pa)	4A (150 Pa)	5A (200 Pa)	6A (250 Pa)	7A (300 Pa)	8A (450 Pa)	9A (600 Pa)	E750 (750 Pa)
	Wind load resistance, max. test pressure ⁽⁵⁾ EN 12211; EN 12210	1 (400 Pa)	2 (800 Pa)	3 (1200 Pa)	4 (1600 Pa)	5 (2000 Pa)	Exxx (1-2000 Pa)				
	Wind load resistance to frame deflection ⁽⁵⁾ EN 12211; EN 12210	A (≤ 1/50 Pa)		B (≤ 1/200 Pa)			C (≤ 1/300 Pa)				
Comfort		PAS 24									
	Burglar resistance ⁽⁶⁾ ENV 1627 - ENV 1630										

This table shows classes and values of performances which can be achieved for specific configurations and opening types.

⁽¹⁾ The Uf-value measures the heat flow. The lower the Uf-value, the better the thermal insulation of the frame.

⁽²⁾ This table shows classes and values of performances which can be achieved for specific configurations and opening types.

⁽³⁾ The air-tightness test measures the volume of air that would pass through a closed window at a certain air pressure.

⁽⁴⁾ The water-tightness test involves applying a uniform water spray at increasing air pressure until water penetrates the window.

⁽⁵⁾ The wind load resistance is a measure of the profile's structural strength and is tested by applying increasing levels of air pressure to simulate the wind force.

⁽⁶⁾ The burglar resistance is tested by static and dynamic loads, as well as by simulated attempts to break in using specified tools. This variant requires specific burglar resistance accessories.

⁽⁷⁾ Please refer to Reynaers' CE passport for all technical data including size limitations.